

ASSEMBLY INSTRUCTIONS:

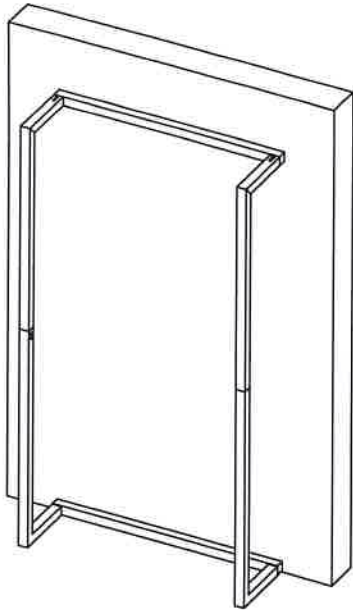

REQUIRED TOOLS NOT INCLUDED

- POWER DRILL
- BUBBLE LEVEL
- WALL ANCHOR HARDWARE WITH A SHEAR RATING OF 60 LBS OR MORE AND A TENSION RATING OF 80 LBS OR MORE. (MAXIMUM HARDWARE DIAMETER 1/4")

2

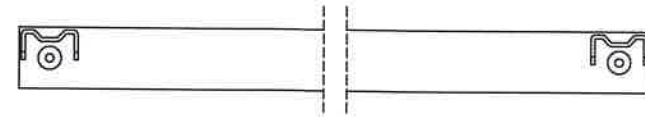

**TOP CROSS BAR
FRONT VIEW**

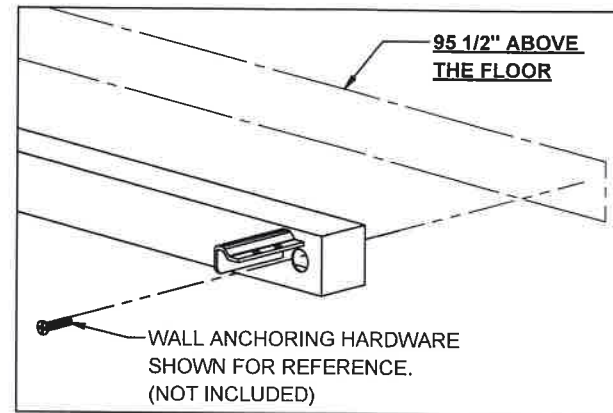

LEVEL AND MOUNT THE TOP CROSS BAR TO THE DESIRED WALL AS SHOWN WITH APPROPRIATE WALL MOUNTING HARDWARE.

1

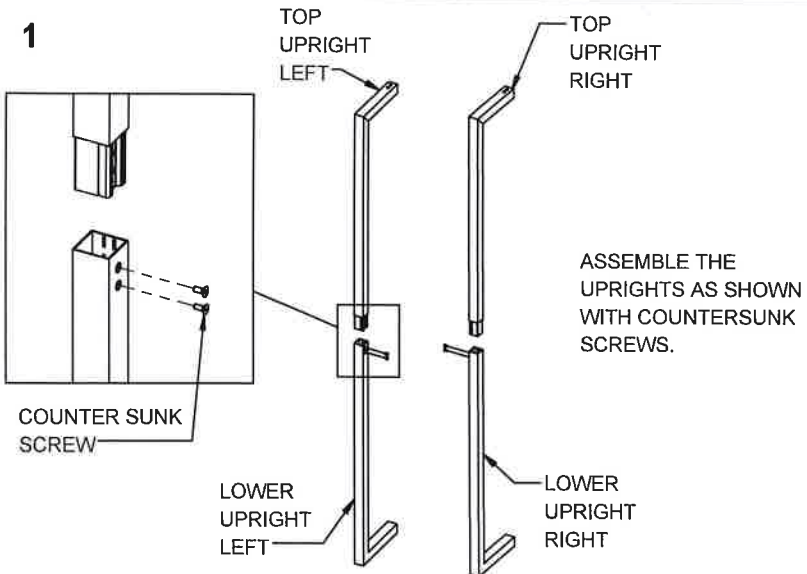

3

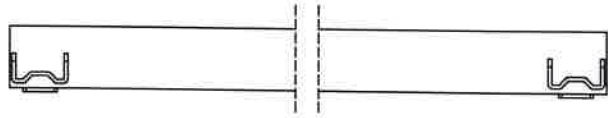

BOTTOM CROSS BAR
FRONT VIEW

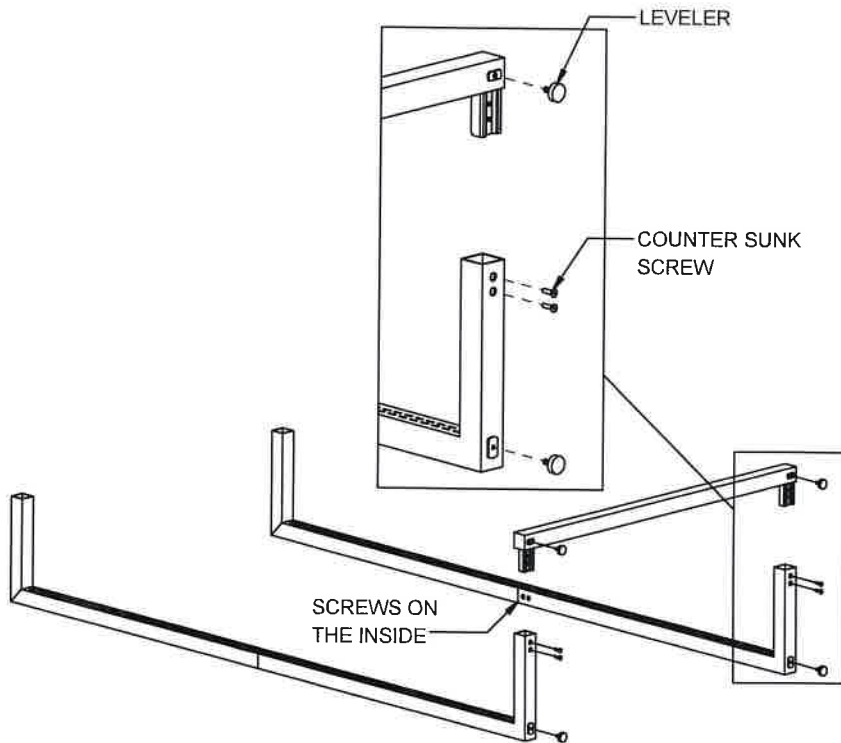

- LAY THE UPRIGHTS ON THE FLOOR AS SHOWN AND ASSEMBLE THE UPRIGHTS WITH THE LOWER CROSS BAR.
- INSTALL THE LEVELERS AS SHOWN.
- NOTE: IT IS RECOMMENDED TO POSITION THE SCREWS ON THE UPRIGHTS TO BE POSITIONED ON THE INSIDE OF THE UNIT, BUT THIS IS NOT REQUIRED.**

4

THIS STEP MAY REQUIRE 2 OR MORE PEOPLE

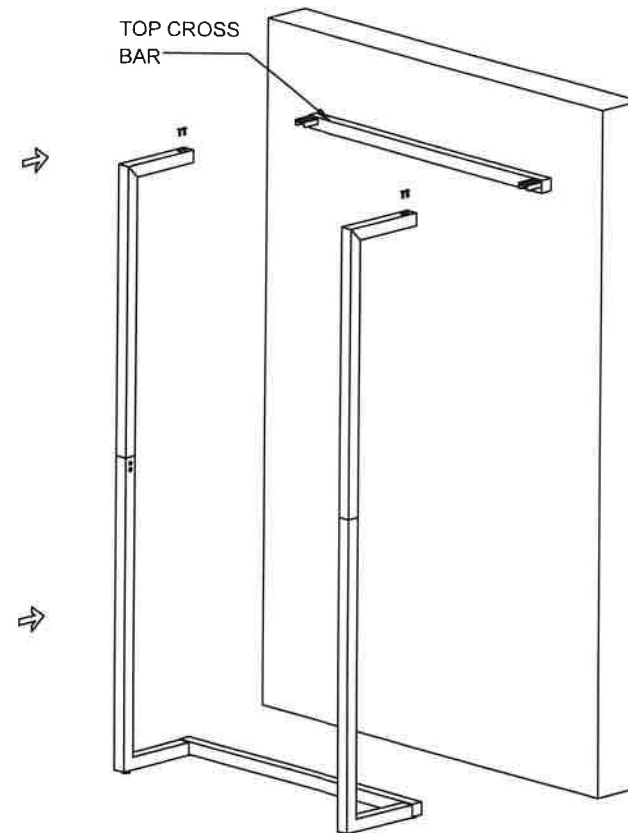

- LIFT THE ASSEMBLED FRAME UP TO THE UPPER CROSS BAR MOUNTED ON THE WALL AND ASSEMBLE AS SHOWN WITH THE REMAINING COUNTER SUNK SCREWS.
- NOTE: BE SURE TO MAKE SURE ALL LEVELERS ARE UNSCREWED ENOUGH TO ALLOW THE UNITS WEIGHT TO BE ON THE FLOOR.**